

# LLHBF SERIES Industrial Lighting

## LLHBF-255-300W-MCTP-SR

LINEAR NSF FOOD HIGHBAY 120/160/200W 3CCT SENSOR READY

**MCTP** Multi Color Temperature & Multi Power/Wattage (Selectable)



Shown With Installed Motion Sensor

The Westgate Linear NSF Food Highbay is an advanced lighting solution designed for food processing facilities, cold storage, commercial kitchens, and other hygiene-sensitive environments. It meets NSF food safety standards and offers high efficiency with superior illumination, durable construction, and an IP69 rating, ensuring it withstands harsh conditions and frequent cleanings. Energy-efficient and long-lasting, this highbay fixture reduces operational costs while providing versatile mounting options and reliable performance in demanding settings.

Customer Name: \_\_\_\_\_

Project Name: \_\_\_\_\_

Note: \_\_\_\_\_

Type: \_\_\_\_\_

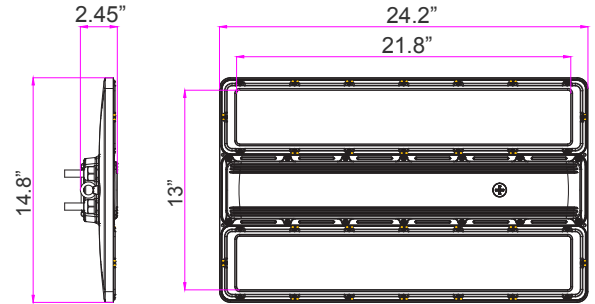

14.8"(H) x 24.2"(W) x 2.45"(D)

## Features

- High Quality LED Chips to Provide High Efficiency, Heat Dissipation
- Stability, and Lumen Maintenance
- Polycarbonate Lens, High Flame Retardant Point
- Frosted Lens
- 50,000 Hours Rated Life
- 5-Year Warranty

## Technical Specifications

### Electrical:

- Voltage: 120~277VAC/50~60 Hz
- Wattage: 255W/280W/300W
- Power Factor: >0.95
- Efficacy: 150 LPW

### Mechanical:

- IP69 Rated: Ensures complete protection against dust and high-pressure water jets
- 3FT, 18AWG SVT AC Power Cable
- Suspended Mount: Two 3.3' Steel Chains, Stainless Steel Ceiling Anchor Hooks, Hanging Rings, & Snap Spring Hooks are included.
- NSF Certified: Compliant with food safety standards for hygienic environments
- Durable Aluminum Housing: Provides robust and corrosion-resistant protection
- Twist-Lock Zhaga Socket Pre-Installed. See Motion Sensor Accessories
- Suspended Mount: Hanging Chains and Rings are included
- Suspended Mount: Two 3.3' Steel Chains, Stainless Steel Ceiling Anchor Hooks, Hanging Rings, & Snap Spring Hooks are included
- Operating Temperature: -22°F ~ 140°F
- Suitable For Wet Locations
- 5-Year Warranty

### Lighting:

- 0-10V dimming info and logo
- Lens: Polycarbonate Lens
- Total lumens: 45000LM (Per Industry Standards, Lumens are Reported Without Frosted Lens)
- Color Temperatures: 4000K/4500K/5000K
- Color Rendering Index: >80
- Wide Beam Angle: 110°x110°

### Applications:

- Food processing facilities
- Cold storage rooms
- Commercial kitchens
- Pharmaceutical manufacturing
- Clean rooms
- Warehouses requiring hygiene standards



## Photometrics: LLHBF-255-300W-MCTP-SR

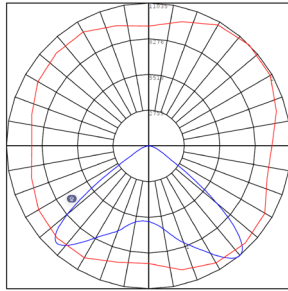
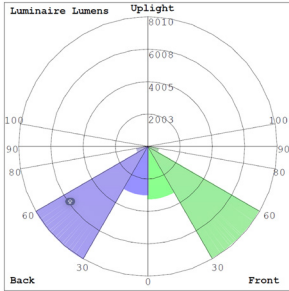

BUG Rating: B4-U2-G1

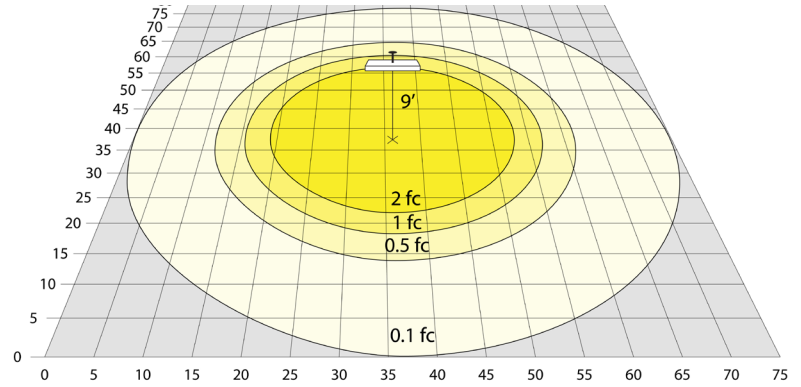

Area 75'x 75' Mounting Height: 9'

## Other Views:



Front View



Side View



Back View

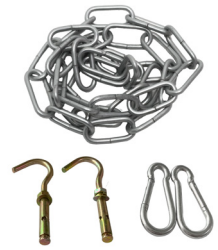

Suspension Accessories Included

## Performance Table: LLHBF-255-300W-MCTP-SR

MODEL NO.	Wattage	Voltage	Lumens	Color Temp.	BUG Rating	LPW
LLHBF-255-300W-MCTP-SR	255W	120~277V	38250LM	4000K	B4-U2-G1	150
	280W		42000LM	4500K		
	300W		45000LM	5000K		

## Sample Ordering

Model Wattage Color Temp. Sensor

LLHBF - 255 - 300W - MCTP - SR

## Factory-Installed Options

Blank = No Option

TOP WEC-3RC = REMOTE CONTROL

WEC-3PR-72-TLB-WH = 600W Max, 3-PIN 12-24VDC PIR SENSOR, BLACK, WITH BASE (OPTIONAL REMOTE CONTROL WEC-3RC)

WEC-3MR-72-TLB-BK-3PIN = 600W Max, 3-PIN 12-24VDC PIR SENSOR, BLACK, WITH BASE (OPTIONAL REMOTE CONTROL WEC-3RC)

WEC-3MBT-72-TLB-BK-3PIN = 600W Max, 3-PIN 12-24VDC PIR SENSOR, BLACK, WITH BASE (OPTIONAL REMOTE CONTROL WEC-3RC)

## EMERGENCY BATTERY BACKUP AND SENSOR OPTIONS:



WEC-3RC



WEC-3PR-72-TLB-WH



WEC-3PR-72-TLB-WH  
WEC-3MBT-72-TLB-BK

